

MODEL 550S

Semi-Automatic Round Product Labeler

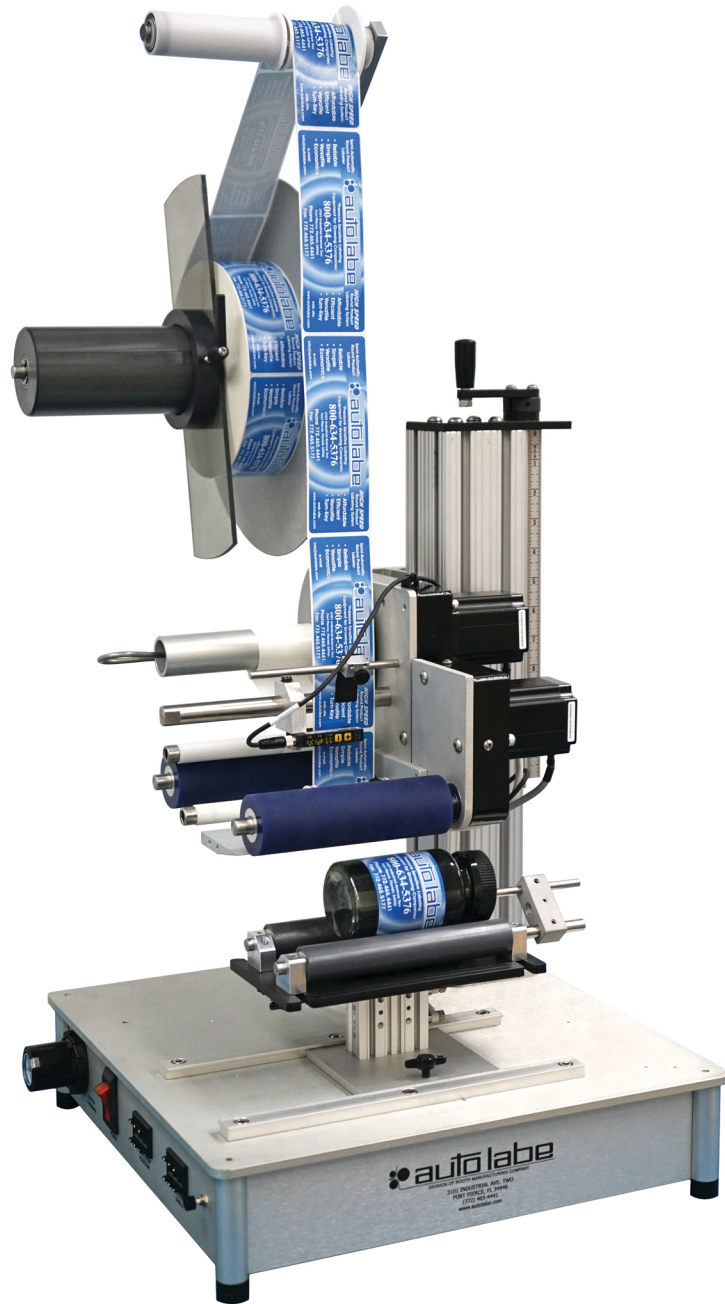

 auto labe

MODEL 550S

Semi-Automatic Round Product Labeler

- Cost effective and time-saving alternative to manual labeling
- Economical for small production runs
- Easy height adjustment for round products from 3/8" to 6" (gallon) diameter
- Portable and lightweight

STANDARD FEATURES:

- PLC controlled
- Stepper label and drive motors
- Photoelectric label sensor
- Foot switch activation
- Label dispense speed of 40ft/min
- Integrated regulator with gauge
- Modular product positioning
- Smart label stop delay
- Label advance switch
- Accommodates various label types

SPECIFICATIONS:

Weight / Dimensions (overall):

Weight: 50lbs.
Width: 18 in. / 45.72 cm.
Length: 25 ½ in. / 64.77 cm.

Shipping weight/dimensions:

55lbs. (approx.)
30" in. cubed / 76.2 cm.

Electric:

110 VAC 50/60Hz / 10 AMP.
220 VAC 50/60Hz / 5 AMP.

Air:

50PSI (min.) to 90PSI (max.)
2CFM

LABEL SPECIFICATIONS:

Standard 6" web width
12" O.D. roll with 3" core
Pressure sensitive / die cut

OPTIONS AVAILABLE:

- Inkjet label coding
- Hot stamp imprinter
- Clear label sensor
- Extra wide label kit
- Front/back labeling
- Resettable counter

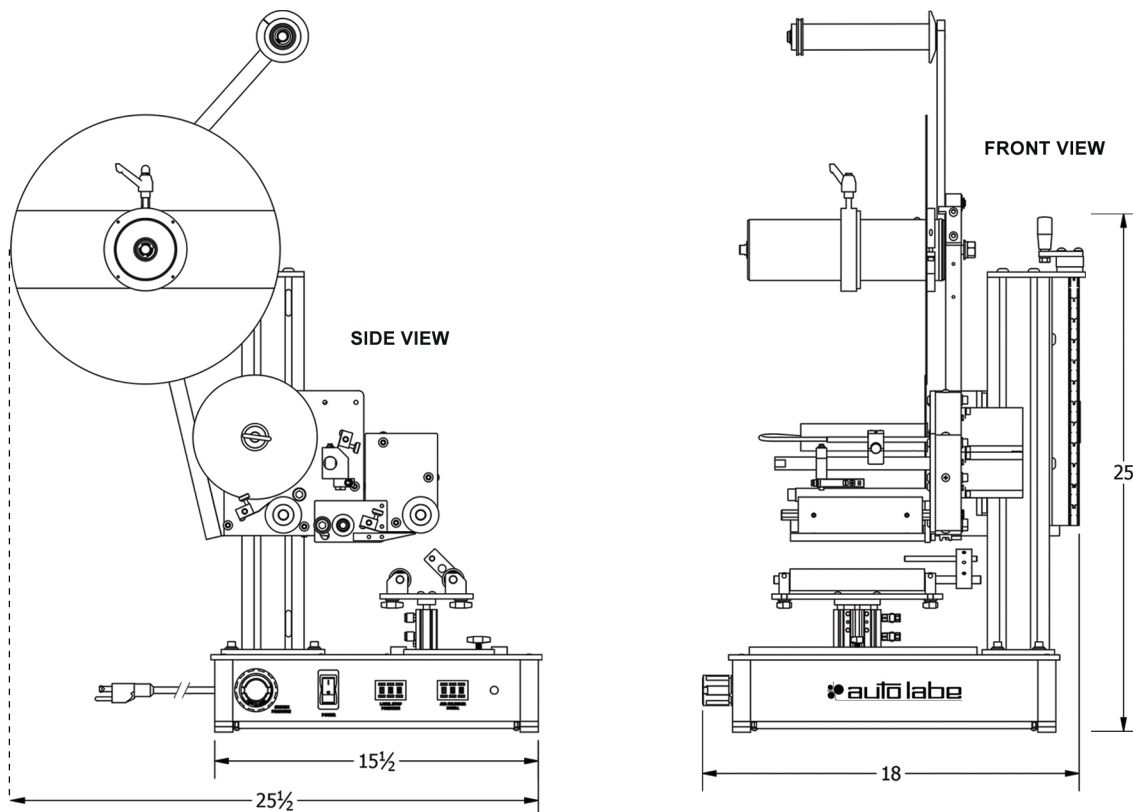

3101 Industrial Avenue Two, Fort Pierce, Florida 34946
772-465-4441 • www.autolabe.com • e-mail: info@autolabe.com